

REVISION RECORD			
REV.	CONTENT	MOD.	DATE
△	初版发行		

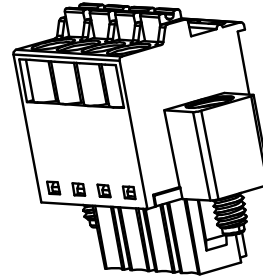

NOTES:
 Pitch : 3.5mm
 Rated Voltage : 300V
 Rated Current : 8A
 Withstand Voltage :
 AC2500V for 1 minute
 Insulation Resistance :
 500MΩ / DC500V
 Using Temperature Range :
 - 40℃ ~ + 105℃
 Wire range : 28~ 16AWG

技术要求:
 间距: 3.5mm
 额定电压: 300V
 额定电流: 8A
 耐电压值: AC2500V/min
 绝缘阻抗: 500MΩ/DC500V
 使用条件: -40℃~+105℃
 适用线规: 28~16AWG

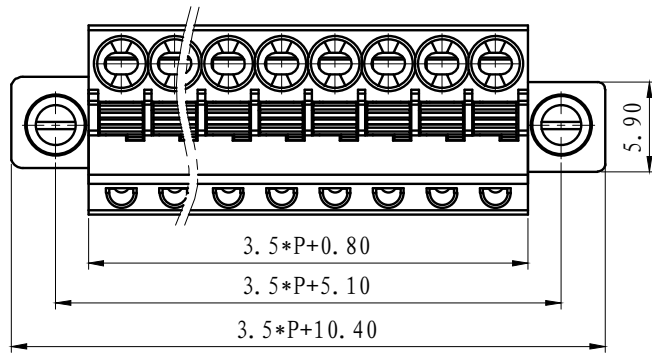
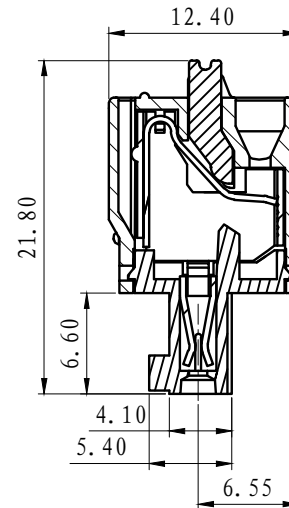
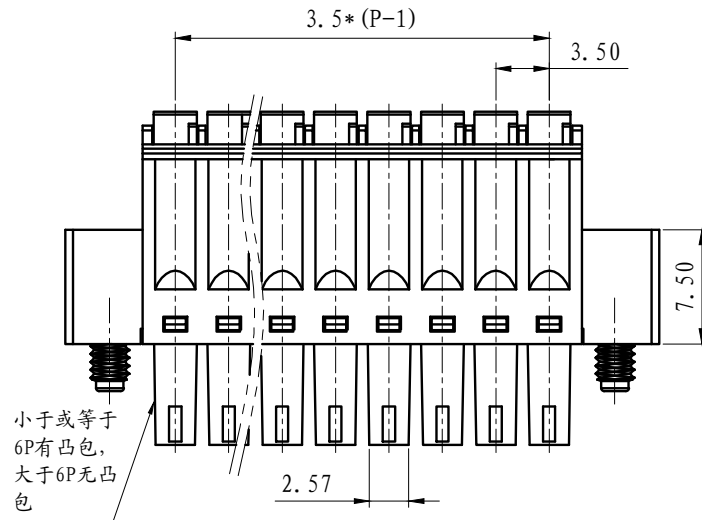

	pitch dimension			Nominal dimension					—
	over 0	over 6	over 10	over 0	over 30	over 60	over 100	over 150	
variable range	to 6	to 10	to 24	to 30	to 60	to 100	to 150		▱
Tolerance	±0.1	±0.15	±0.25	±0.2	±0.3	±0.5	±0.7	±1.0	○

6	LC1-耳朵螺丝	SP0YA255101V	2	碳钢	三价铬钝化彩锌
5	LC6-3.81-弹片	F2A0DLC638BV	P	不锈钢	
4	LC6-3.81-夹子	1043B0001AV	P	磷青铜	镀镍
3	LC6-3.81-按钮	1043D0YXXAV	P	POM	
2	LC6-3.5-盖板	1113C0YXXAV	1	PA66	
1	LC6M-3.5-主体	1113M0YXXAV	1	PA66	
NO.	NAME OF PART	NO. OF PART	Q'TY	MATERIAL	NOTES
DES.	LDD	DATE	2013-7-3	UNITS	mm
CHK.		DATE		SIZE	A4
APP.		DATE		SCALE	1:1
				DWG NO.	SP-2-1113002
				TITLE	LC6M-3.5-XXP-1Y-00A
					LC6M-3.5-成品



上海联捷电气有限公司
 Shanghai Elinker Electric CO.,LTD

TITLE

LC6M-3.5-XXP-1Y-00A
 LC6M-3.5-成品

REVISION RECORD			
REV.	CONTENT	MOD.	DATE
△	初版发行		

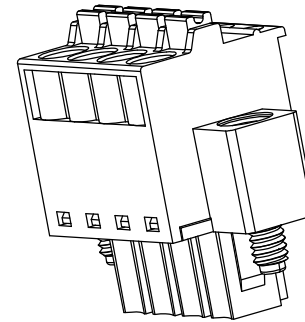
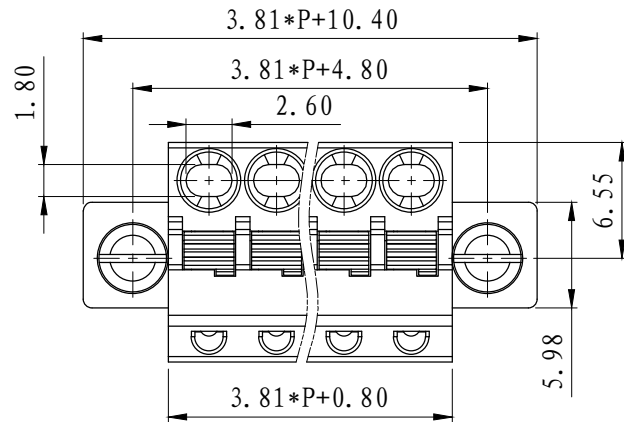

NOTES:
 Pitch : 3.81mm
 Rated Voltage : 300V
 Rated Current : 8A
 Withstand Voltage :
 AC2500V for 1 minute
 Using Temperature Range :
 - 40°C ~ + 105°C
 Wire range : 28~ 16AWG

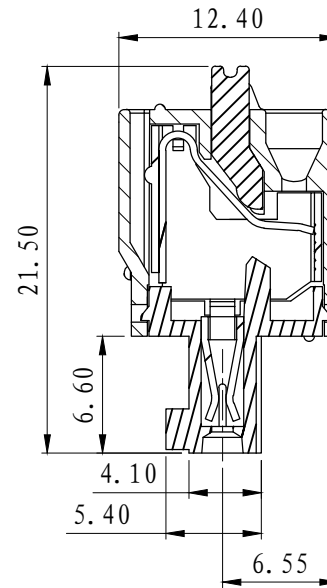
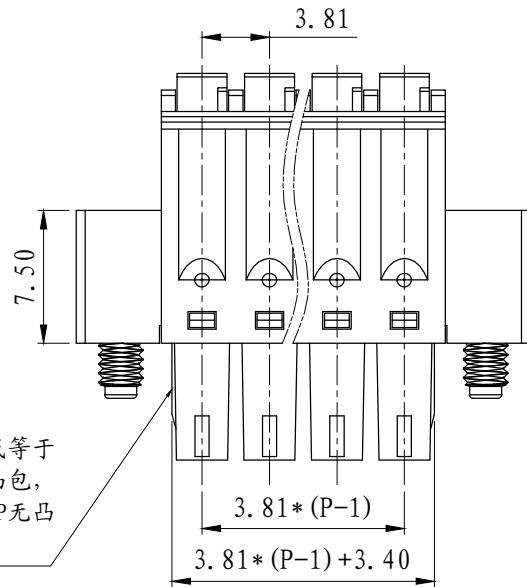

技术要求:
 间距: 3.81mm
 额定电压: 300V
 额定电流: 8A
 耐电压值: AC2500V/min
 使用条件: -40°C ~ +105°C
 适用线规: 28~16AWG

	pitch dimension			Nominal dimension					—
	over 0	over 6	over 10	over 0	over 30	over 60	over 100	over 150	
variable range	to 6	to 10	to 24	to 30	to 60	to 100	to 150		
Tolerance	±0.1	±0.15	±0.25	±0.2	±0.3	±0.5	±0.7	±1.0	0.05/10

6	LC1-耳朵螺丝	SP0YA255101V	2	碳钢	三价铬钝化彩锌
5	LC6-3.81-弹片	F2A0DLC638BV	P	不锈钢	
4	LC6-3.81-夹子	1043B0001AV	P	磷青铜	镀镍
3	LC6-3.81-按钮	1043D0YXXAV	P	POM	
2	LC6-3.81-盖板	1043C0YXXAV	1	PA66-V0	
1	LC6M-3.81-主体	1043M0YXXAV	1	PA66-V0	
NO.	NAME OF PART	NO. OF PART	Q'TY	MATERIAL	NOTES
DES.	CMZ	DATE	25/01/03	UNITS	mm
CHK.	HH	DATE	25/01/03	SIZE	A4
APP.		DATE		SCALE	
				DWG NO.	SP-2-1043001
				REV:	V0
上海联捷电气有限公司 Shanghai Elinker Electric CO.,LTD				TITLE	LC6M-3.81-XXP-1Y-00A
					LC6M-3.81-成品